

Dual-line lubrication system

Pump models ZPU 08, ZPU 14, and ZPU 24
EMU 3 change-over valve
VSG metering devices



System benefits

- Exactly metered amount of lubricant supplied to lubrication points
- Continued lubrication even in case of blockage at one point
- Highly reliable and long service life of components
- Suitable for harsh conditions -, such as dirty and dusty environment and low temperatures

Features

- Simple, accurate and individual metering of lubricant volumes for each pair of outlets
- Up to 2 000 lubrication points over long distances
- Extension of lubrication system can be easily done
- Visual or electrical monitoring of each pair of outlets
- Intelligent control unit automatically applies minimum required system pressure thus increasing service life of individual components
- The metering devices are provided with lubricant from two main lines whereby the lubricant also serves as a means of control for the system
- The dual-line system can be combined with downstream progressive metering devices thus increasing the total number of lubrication points that can be provided with lubricant by the dual-line metering device.



ZPU 08 with 100 l reservoir

ZPU 08 | 14 | 4

The electrically operated high-pressure pumps, type ZPU 08, ZPU 14, and ZPU 24, are standard supply pumps in dual-line systems. Thanks to their supply and pressure range, they suit also extended systems with line lengths of up to 120 m.

The pumps are state-of-the-art and very reliable with a particularly long service life. All main components are easily accessible. The pumps are equipped with a pressure relief valve, a check valve, a lubrication filter, and a pressure gauge as a standard.

Technical data

Flow rate	8/14/24 dm ³
Operating pressure	max. 400 bar
Operating temperature	-20 to +80 °C
Reservoir capacity	40 l or 100 l

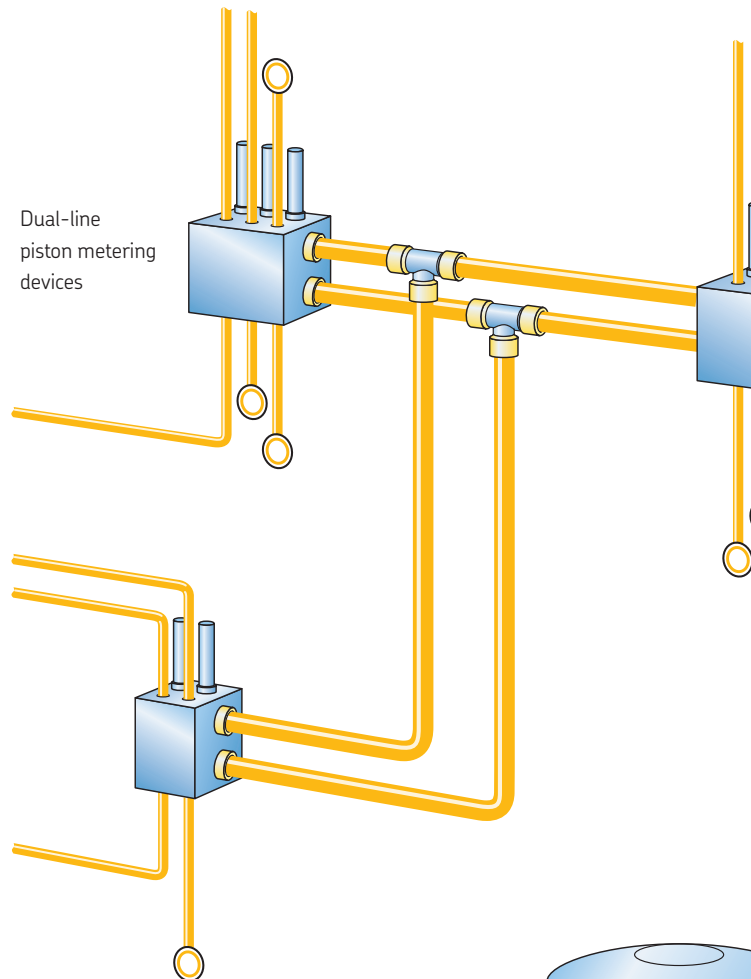

Dual-line piston metering devices

Pump piston unit

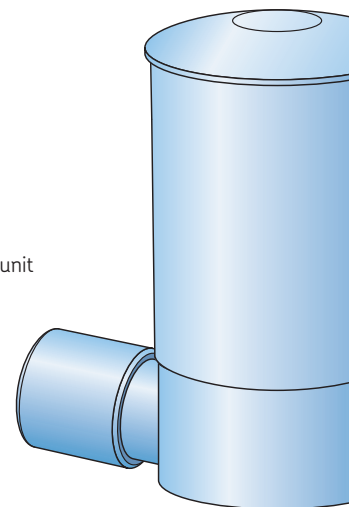

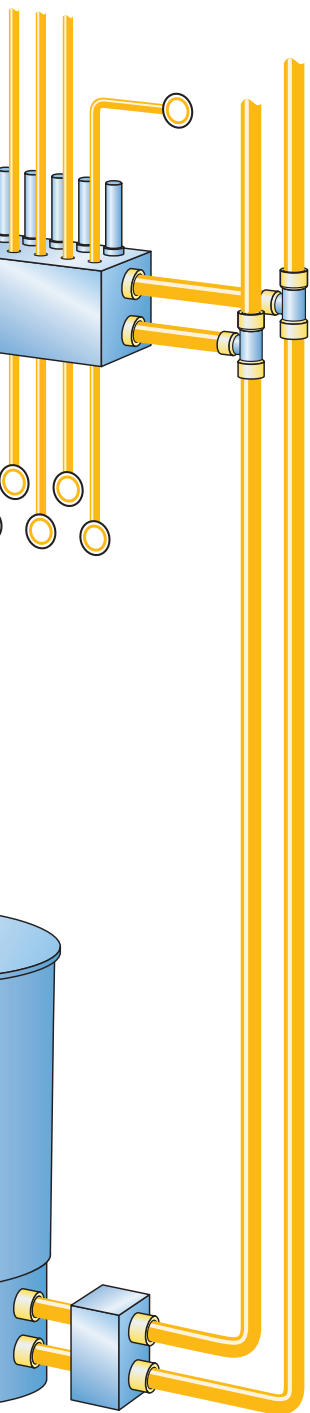

Change-over valve

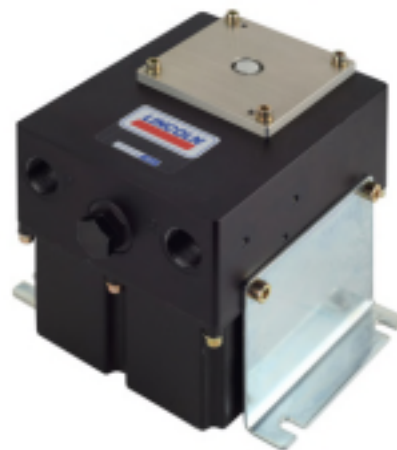

EMU 3

EMU 3 change-over valve

Electrically operated, for use with dual-line systems

Applications

The EMU 3 change-over valve is particularly suitable for extended dual-line systems also in combination with pneumatically operated supply pumps with large flow rates.

System benefits

The change-over valve has a mid position with the option to relieve both main lines (A and B) towards the pump reservoir (R) during the pause time.

As a consequence, the system components are pressurized for a shorter period of time and have a longer service life. Furthermore, the lubricant is not pressurized unnecessarily long. Thus, the risk of bleeding (separation of soap and oil) is smaller.

A large connection thread and the distances allow tubes to be connected with a larger diameters of up to 30 mm without any problem.

Technical data

Flow rate for grease	400 dm ³ /h
Operating pressure	max. 400 bar
Operating temperature	-20 to + 80 °C
Connection thread	G 3/4"
Voltage	24 V DC
	100 – 230 V AC

VSG Dual-line metering devices

These high-quality, galvanized steel metering devices are designed for high-pressure dual-line systems.

The metering devices of the VS family are available with up to 8 outlets. Each pair of outlets is equipped with an indicator pin for visual monitoring.

Additionally, the dual-line metering devices are available with electrical monitoring by means of low-wear proximity switches (piston detectors).

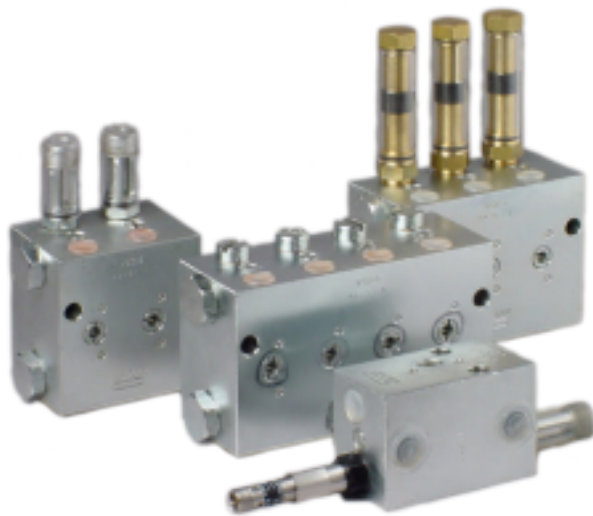

Technical data

Number of outlets	1 – 8
Operating pressure	max. 400 bar
Operating temperature	-20 to +120 °C
Connecting thread	G 3/8"

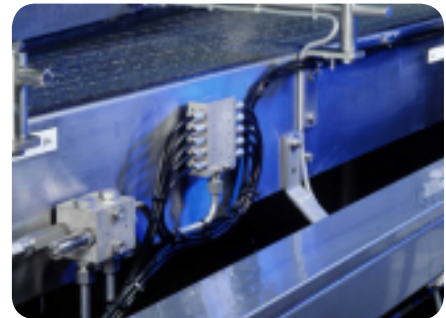

SKF Lubrication Systems Germany GmbH

Heinrich-Hertz-Str. 2-8 · 69190 Walldorf

Germany

Tel +49 6227 33-0

Fax +49 6227 33-259

This brochure was presented to you by:

© SKF is a registered trademark of the SKF Group

© Lincoln is a registered trademarks of Lincoln Industrial Corp

© SKF Group 2014

The contents of this publication are the copyright of the publisher and may not be reproduced (even extracts) unless prior written permission is granted. Every care has been taken to ensure the accuracy of the information contained in this publication but no liability can be accepted for any loss or damage whether direct, indirect or consequential arising out of the use of the information contained herein.

SKF PUB LS/P2 13633 EN · December 2014 · FORM W-209-EN-1214

